



SERVICE PROVIDER
FOR
FAMILY AMUSEMENT



SPORTS ADVENTURE AND CHILDREN PLAY





1993 SINCE

50,000 sqft
MANUFACTURE FACILITY

10000 +
PROJECTS

56 +
CIYY

35 +
CREATIVE DESIGNERS

26 +
IN-HOUSE ENGINEERS

30 +
YEARS OF EXPERIENCE

CONTENTS

1 **COMPANY PROFILIE** 3-4

2 **OUR FACTORY** 5

3 **CHILDREN PLAY** 6-26

4 **SPORTS ADVENTURE** 27-47

5 **FAQ** 48-49

6 **PROJECT INSTALLATION** 50

ABOUT US

Adler has over 30 years of experience specializing in the indoor playground industry. We offer a comprehensive, one-stop service that spans from planning, R&D, production, transportation to construction. Our projects cover a wide range, including themed art decoration, premium soft play sports parks.

01

ENVIRONMENTAL DECORATION



02

HIGH QUALITY INDOOR PLAYGROUND

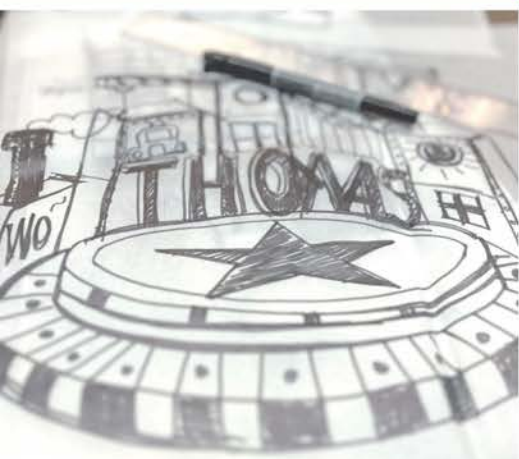

Custom Design



Professional



- Amusement Park Themed Decoration
- High-Quality Soft Play
- Fashionable Sports Center



03

SPORTS ADVENTURE



Service Provider
For Family
Amusement



04

INDOOR UNPOWER



Craftsman
Team



COMPANY INTRODUCTION

History: Established in 1993, Adler has over **30** years of experience specializing in the indoor playground industry. We offer a comprehensive, one-stop service that spans from planning, **R&D**, production, transportation to construction. Our projects cover a wide range, including themed art decoration, premium soft play sports parks.



1993

ESTABLISHED IN 1993

Location: Headquartered in Beijing, Adler employs over **200** staff members and operates a 50,000-square-meter production facility. With more than 30 years of dedication and innovation in FEC industry, we have established strategic partnerships with leading corporations and franchise brands, successfully launching over **6,000** projects worldwide.



MOR THAN **200** EMPLOYEES

Slogan: Adhering to the slogan of "**Pursuing high quality and dedicated to making every amusement park a landmark destination,**" Adler has earned an excellent reputation among both local and international customers.



50,000 m²
SQUARE METERS



OUR QUALIFICATION



Quality • Service • Credit Enterprise



OUR FACTORY

01



02



03



04



05



06

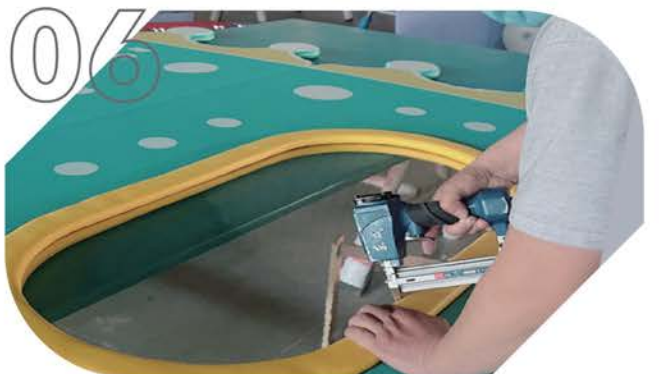

CHILDREN PLAY



 **Beijing**

Size: 1100m² X H:3.5m

Age group: 5-16 years old



NINJA ZONE



KAKA STAR



Baoding

Size: 500m² X H:3.5m

Age group: 3-8 years old



 **Kyrgyzstan**

SKY PARK

Size: 1200m² X H:4.5m

Age group: 3-8 years old



 **Kyrgyzstan**

Size: 1200m² X H:4.5m

Age group: 5-12 years old

SKY PARK

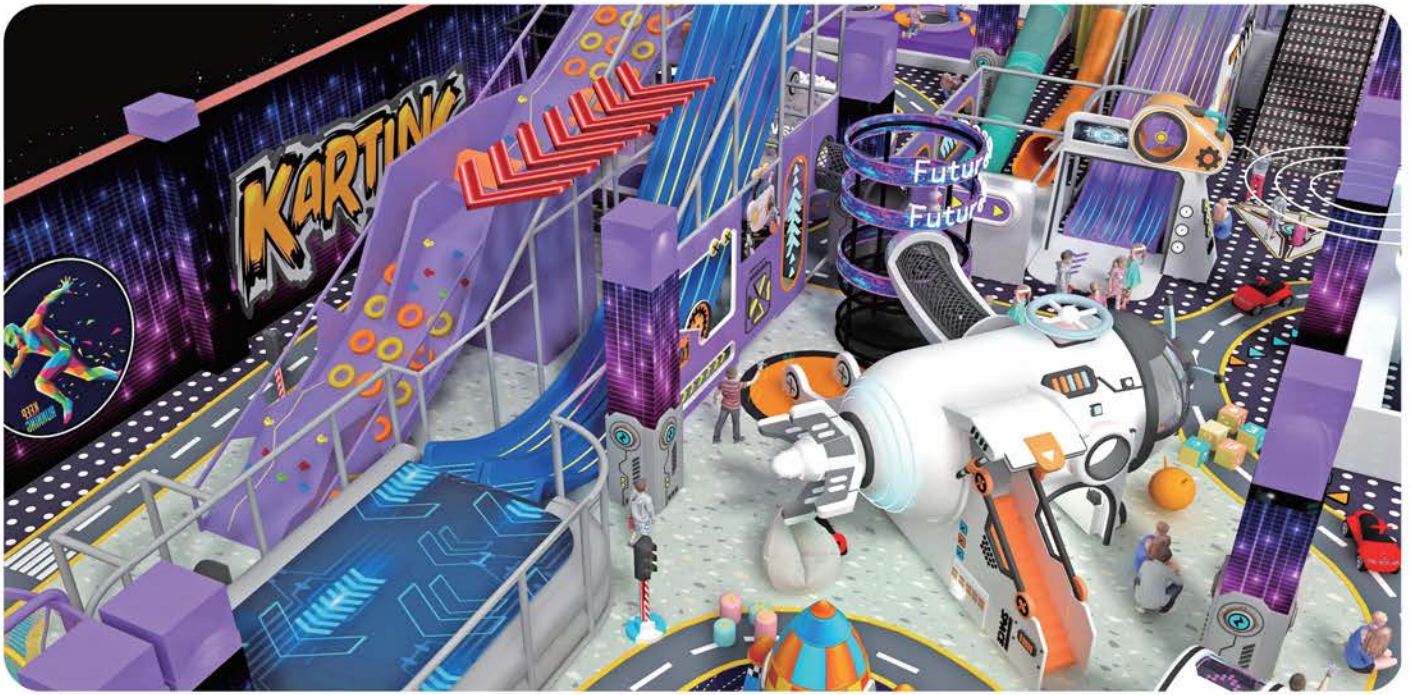

The designer added Rococo design style and used shell and pearl design elements to add to the children's playground, making the whole park look more refined and interesting.



YUNCHENG PLAYGROUND

 **Shanxi**

Size: 500m² X H:4.0m

Age group: 3-8 years old



 **Peru**

FUTURE SPACE

Size: 350m² X H:3.0m

Age group: 3-8 years old



Malaysia

Size: 180m² X H:4.5m

Age group: 3-12 years old

Kidz World



Wuhan

Size: 1000m² X H: 3.5m

Age group: 5-16 years old

SAIER CITY

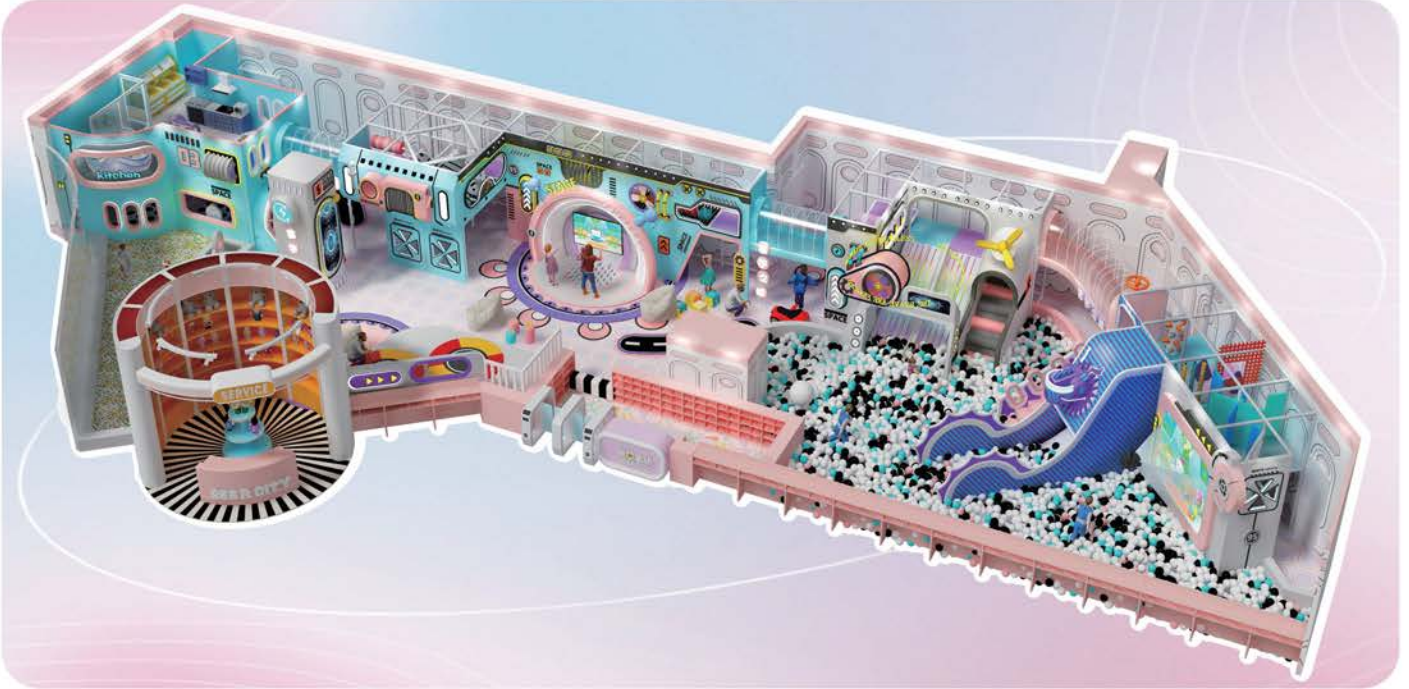

Thailand

Size: 450m² X H:4.5m

Age group: 3-10 years old

OCEAN PARK



Designed as an elevated family experience to provide a safe and imaginative place for children and a supportive and peaceful retreat for caregivers.



KIDS & COFFEE



 **USA, California**

Size: 450m² X H:4.5m

Age group: 3-10 years old



SPACE STATION

Size: 230m² X H:3.6m

Age group: 5-12 years old

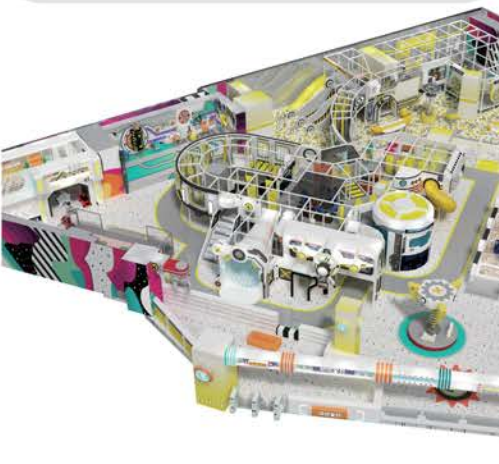
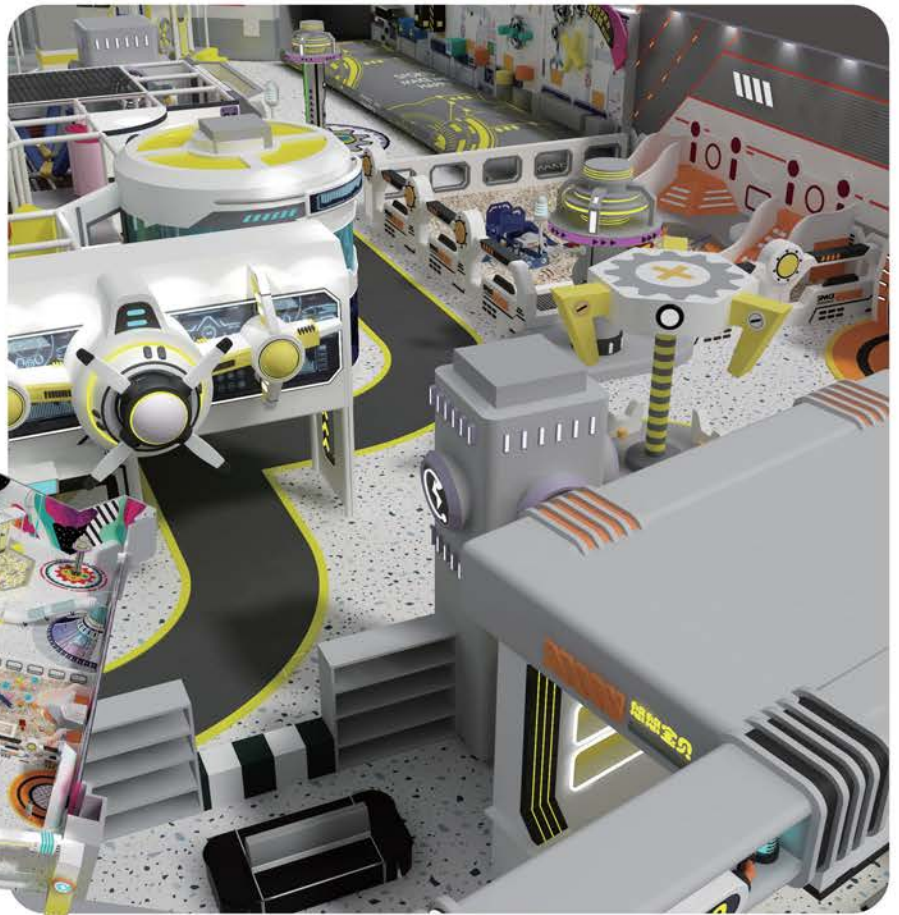
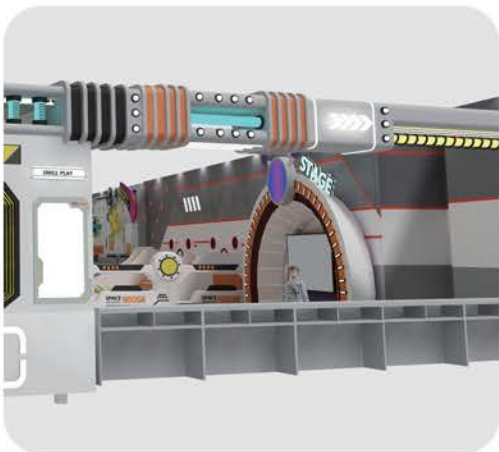



 **Malaysia**

Size: 450m² X H:4.5m

Age group: 3-10 years old

SPORTS PANDA



 **Phuket, Thailand**

MODERN ART

Size: 450m² X H:4.5m

Age group: 3-10 years old



 **Ningbo**

Size: 450m² X H:4.5m

Age group: 3-10 years old

DREAM GARDEN

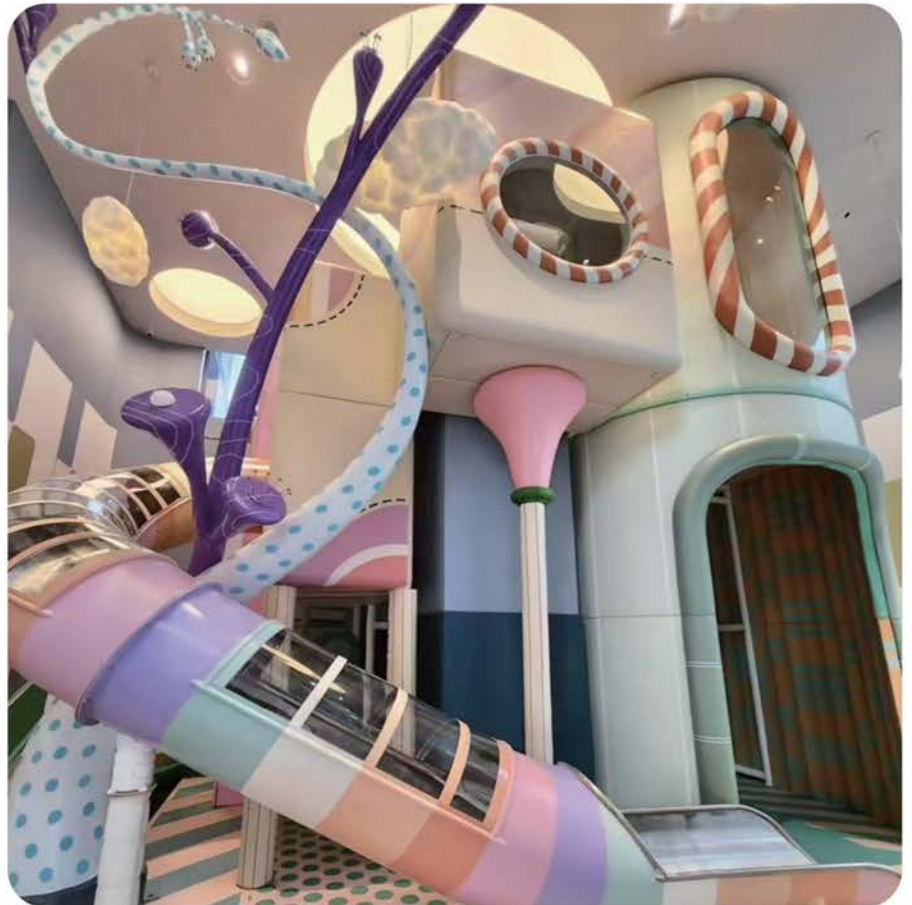
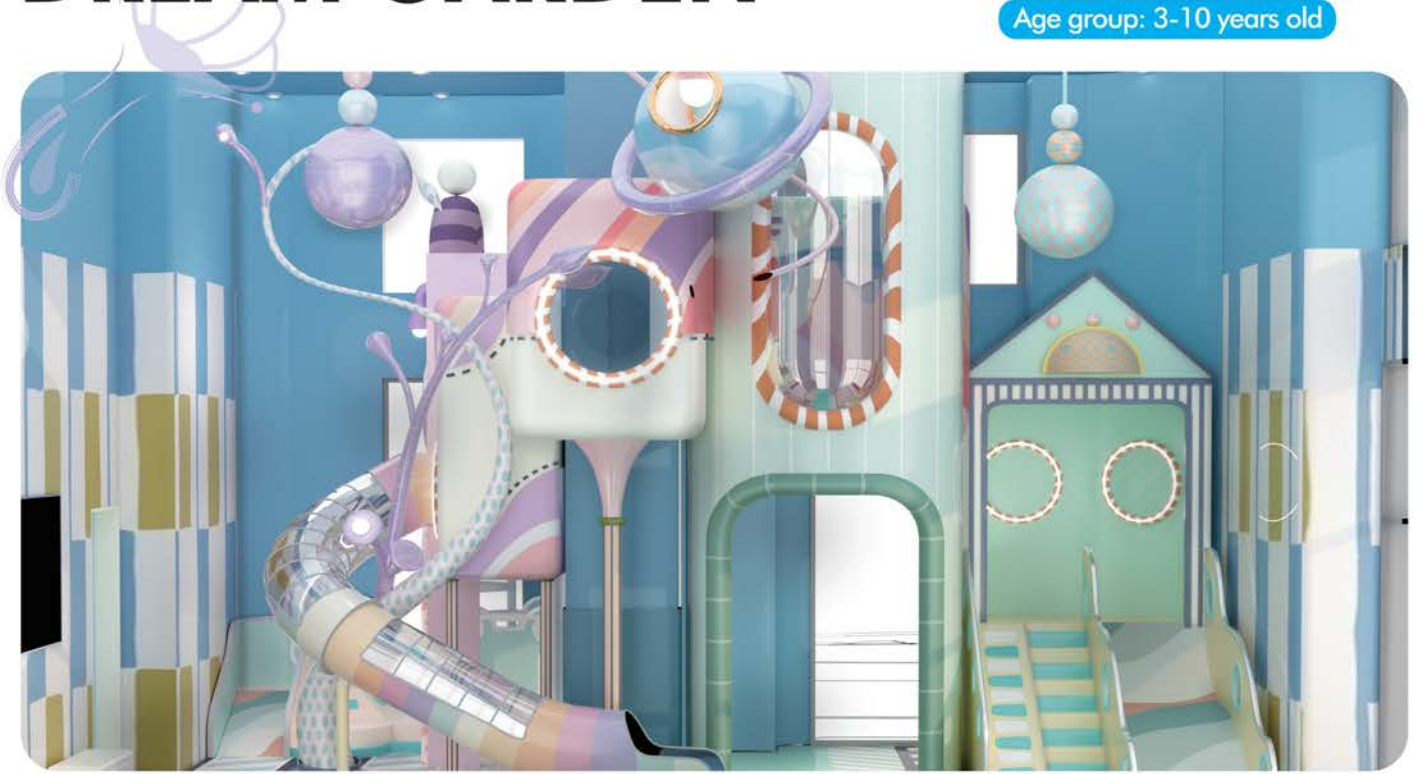

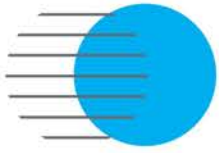

SOFT PLAY

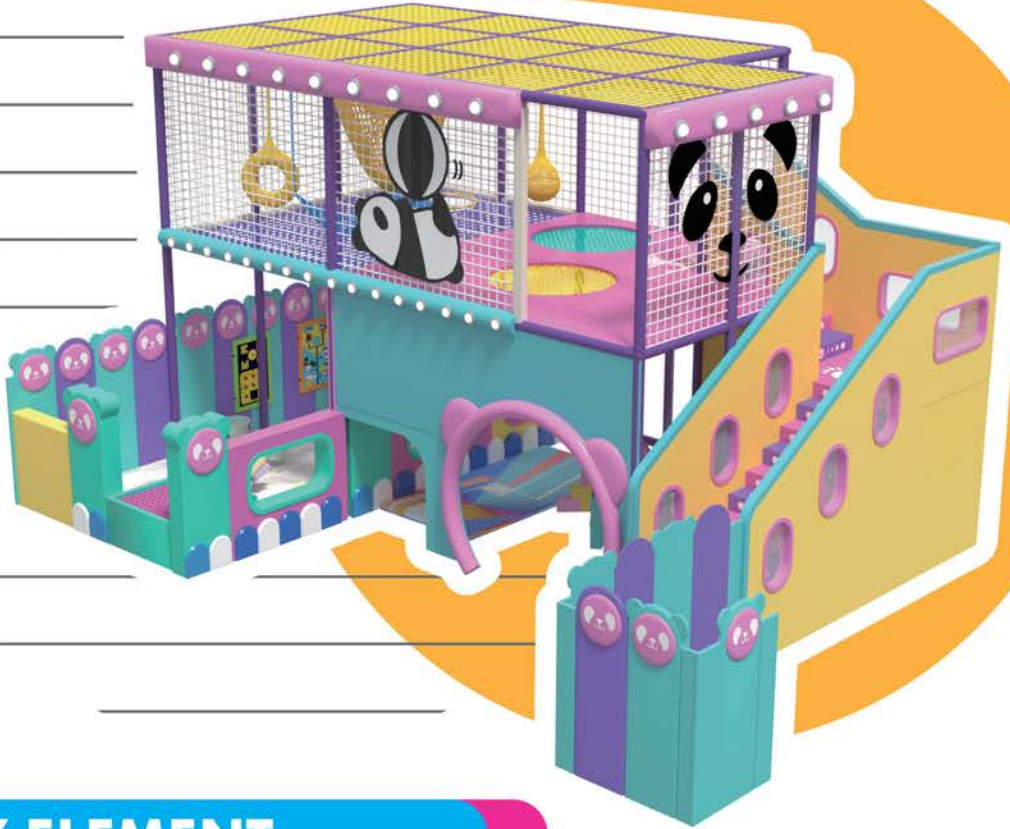

PLAY ELEMENT

HANGING BAG



CROSS HANGING BAGS



ZIP LINE

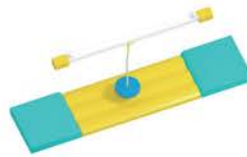

LOG SWING

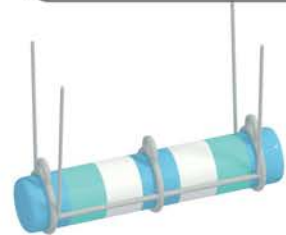

ROPE MAZE

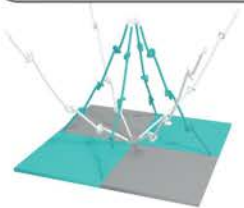

LED LIGHTING DECK

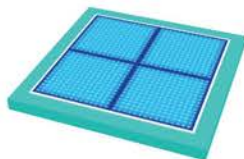

CROSS REVOLVING DOOR



MAGIC DRAWING DECK



RECTANGLE OBSTACLE



WEDGE OBSTACLE



BLOCK BUSTER



MIRROR MAZE



DONUT RING



REVOLVING DOOR



OCTOPUS BALL



SUBULATE OBSTACLE - DOUBLE



FOOTPRINT OBSTACLE



SPACE OBSTACLE

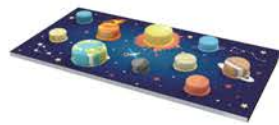

CRAWL WEB

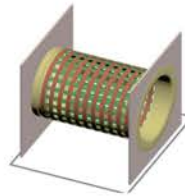

SPIDER NET

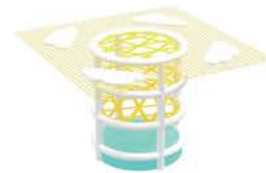

WEB DECK

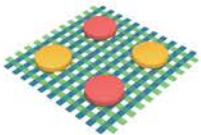

HANGING DECK

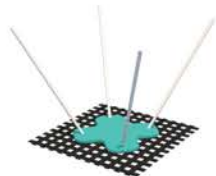

HANGING DECK



WAVE WEB



ZIP LINE



V- BRIDGE



CRAWL TUNNEL

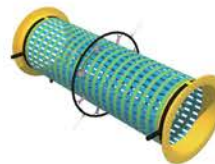

CRAWL TUNNEL WITH WINDOW



SEAT BRIDGE



X- CROSS BRIDGE

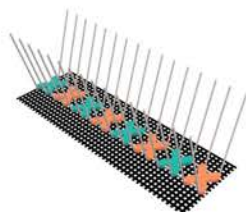

ARC WEB BRIDGE



RODEO RIDER

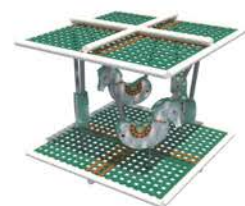

Electrical game

MERRY - GO - ROUND



LADYBUG BROTHERS



MERRY-GO-AROUND



CAROUSEL



Interactive ball pit game

BALL BLASTER



BALL CHALLENGING GAME-A



BALL CHALLENGING GAME-B



ROTATING ROLLER

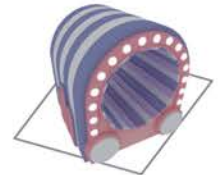

INTERACTIVE BLOWING BALL GAME-A



INTERACTIVE BLOWING BALL GAME-B



INTERACTIVE BALL GAME



CYBER RUNNING MACHINE

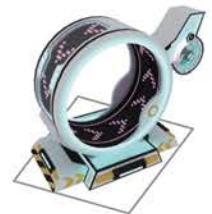

OTHERS

SAND PIT TRUCK



SAND PIT TRAILER



PLASTIC CLIMBING MOUNTAIN



PLASTIC HORN GAME



2.5m VOLCANO SLIDE



3.5m VOLCANO SLIDE



CLIMBING MOUNTAIN

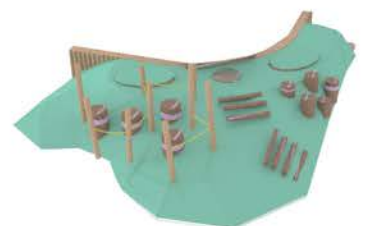

TODDLER GAME

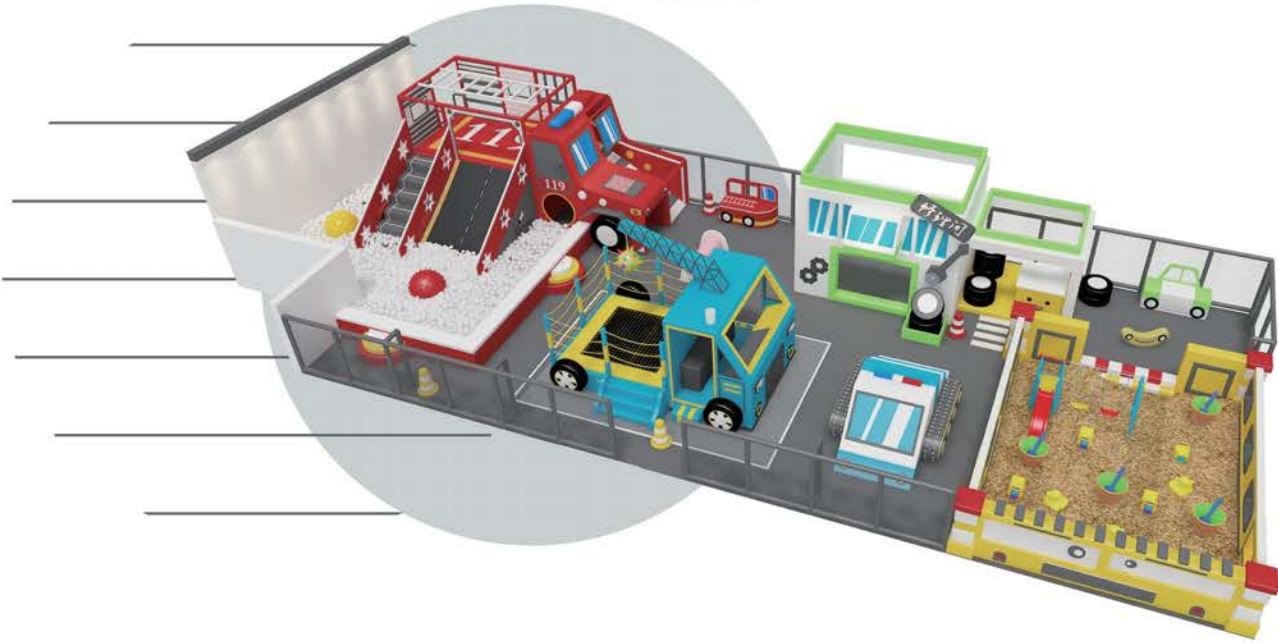

A-SP-01



A-SP-02



A-SP-03



A-SP-04





SPORTS

Name: Parkour

Size: 600m²+ / H:6.0+m

Age group: 10~18+ years old

ADLER
Innovative Research®

Developed by the
ADLER Design Team©



Name: Parkour

Size: ~300m²+ /H:~4.0m

Age group: 3-10 years old

ADL-PK-A

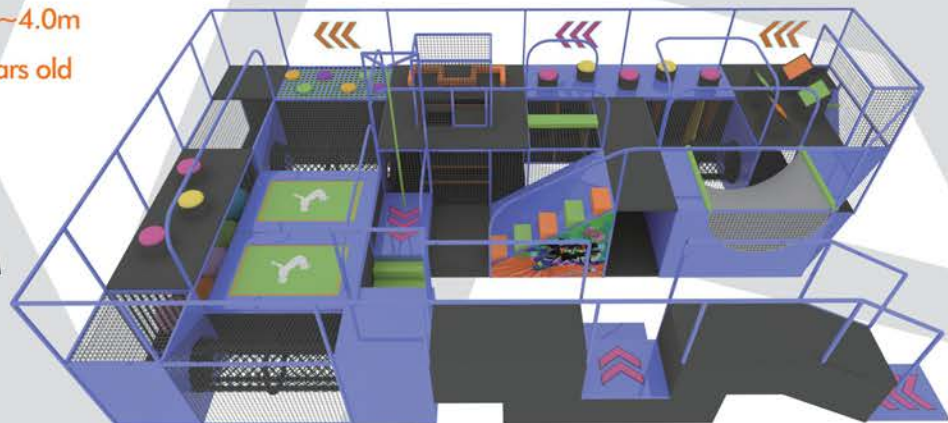

ADVENTURE



ADL-PK-B

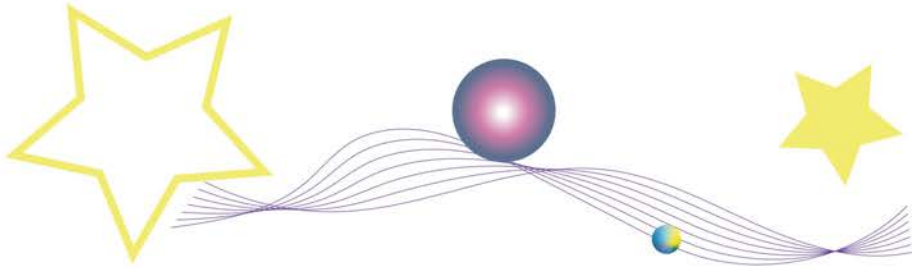

Haerbin

Size: 900m² X H:9.5m

Age group: 5-18 years old



MEXICAN STYLE

 **Colombia**

Size: 450m² X H:4.5m

Age group: 3-10 years old



 **Malaysia**

WONDER PARK

Size: 450m² X H:4.5m

Age group: 3-10 years old

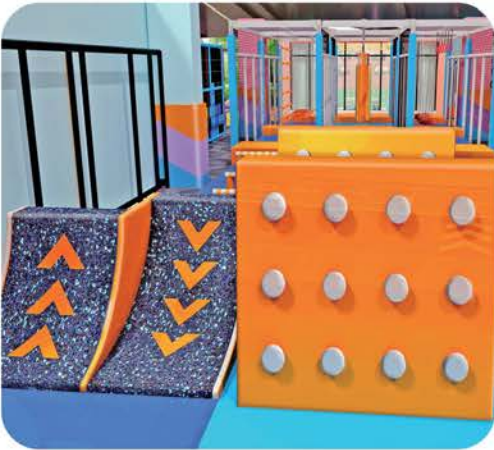

ADVENTURE PARK



Dalian

Size: 1100m² X H:4.0m

Age group:5-12 years old



JUMPY PARK



 **Romania**

Size: 1000m² X H:8.5m

Age group: 5-18 years old



SPORT STARS

Malaysia

Size: 450m² X H:4.5m

Age group: 3-10 years old



TRAMPOLINE

1. High Performance Trampoline
2. Basketball Trampoline
3. Interactive Trampoline
4. Sticky Wall
5. Falling Pit
6. Spider Tower Trampoline
7. Hexagon Trampoline
8. Battle Trampoline
9. Waterfall Trampoline
10. Free Jumping Trampoline
11. Bounce game
12. V- shape Trampoline
13. Dodgeball Area
14. Foam Pit Area

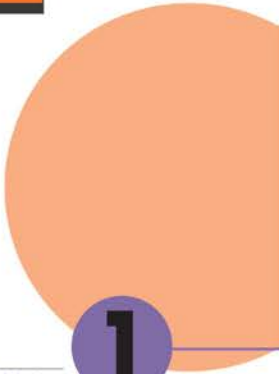

1

5+ 2
H=1m
L=6.6m
W=6.6m



13

5+ 20
H=1m
L=6.6m
W=6.6m

14

5+ 8
H=3.1m
L=6.6m
W=6.6m

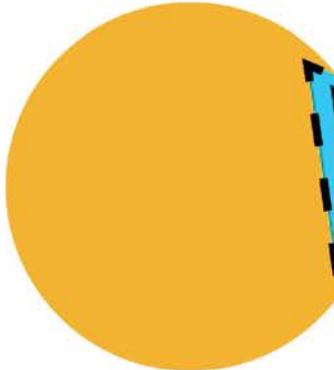

12

5+ 3
H=3.5m
L=2.52m
W=2.52m

11

8+ 2
H=3.5m
L=2.52m
W=2.52m

10

5+ 15
H=2.52m
L=2.52m
W=1m

PARK 3

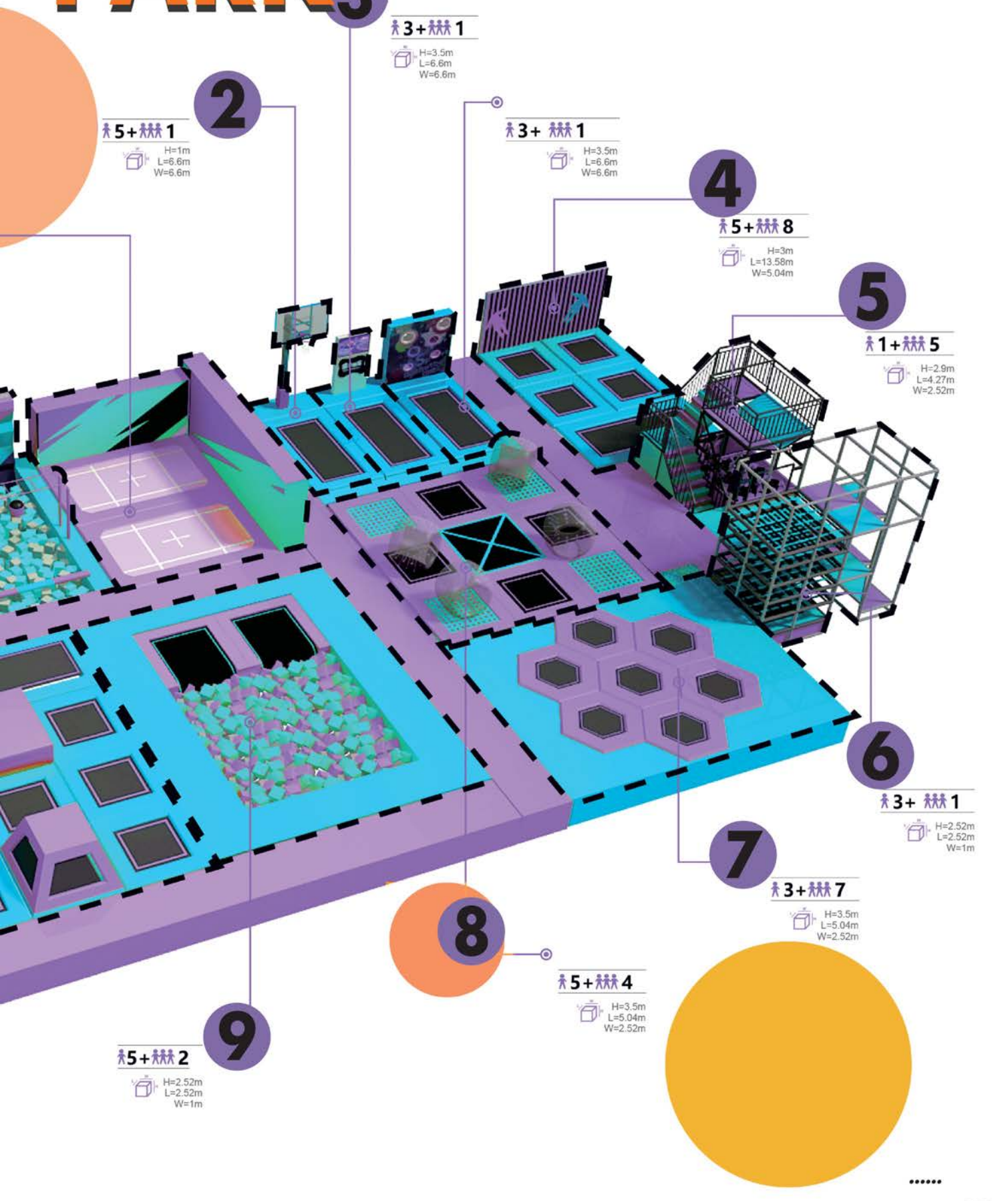

2
5+ 1
H=1m
L=6.6m
W=6.6m

3
3+ 1
H=3.5m
L=6.6m
W=6.6m

3
3+ 1
H=3.5m
L=6.6m
W=6.6m

4
5+ 8
H=3m
L=13.58m
W=5.04m

5
1+ 5
H=2.9m
L=4.27m
W=2.52m

6
3+ 1
H=2.52m
L=2.52m
W=1m

7
3+ 7
H=3.5m
L=5.04m
W=2.52m

8
5+ 4
H=3.5m
L=5.04m
W=2.52m

9
5+ 2
H=2.52m
L=2.52m
W=1m

Sports Adventure

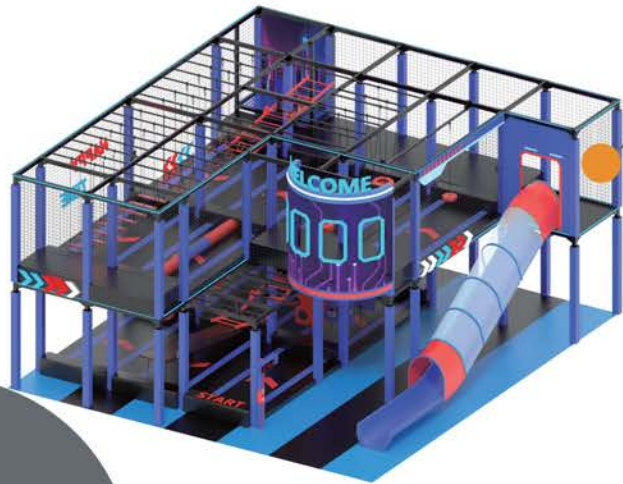

Ninja Course

Basic parameters and specifications

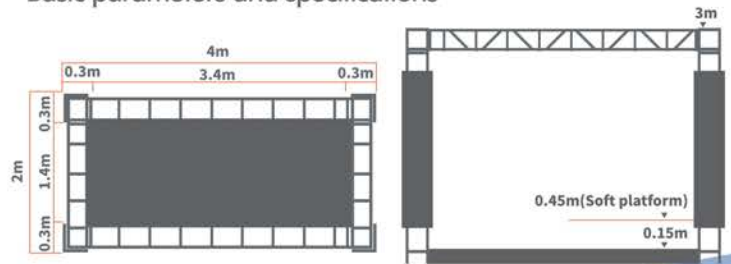

Trampoline

Basic parameters and specifications

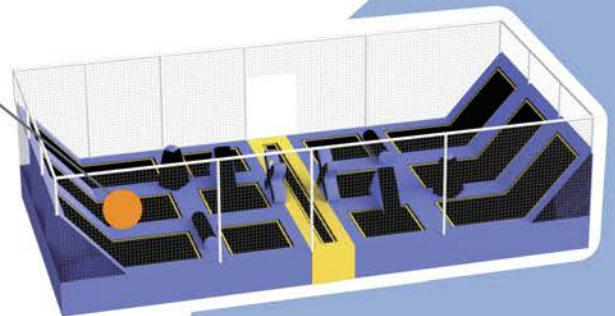

Hive Maze

Basic parameters and specifications

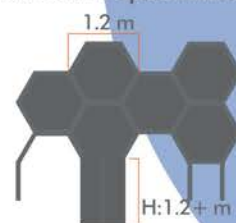

Dount Slides (Air Bag)

Basic parameters and specifications

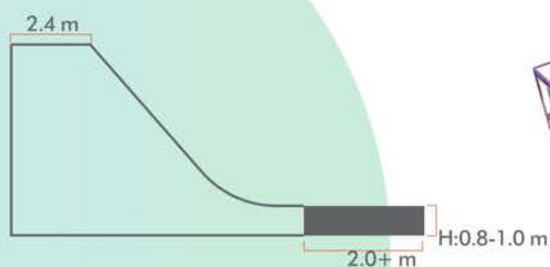

Rope Course

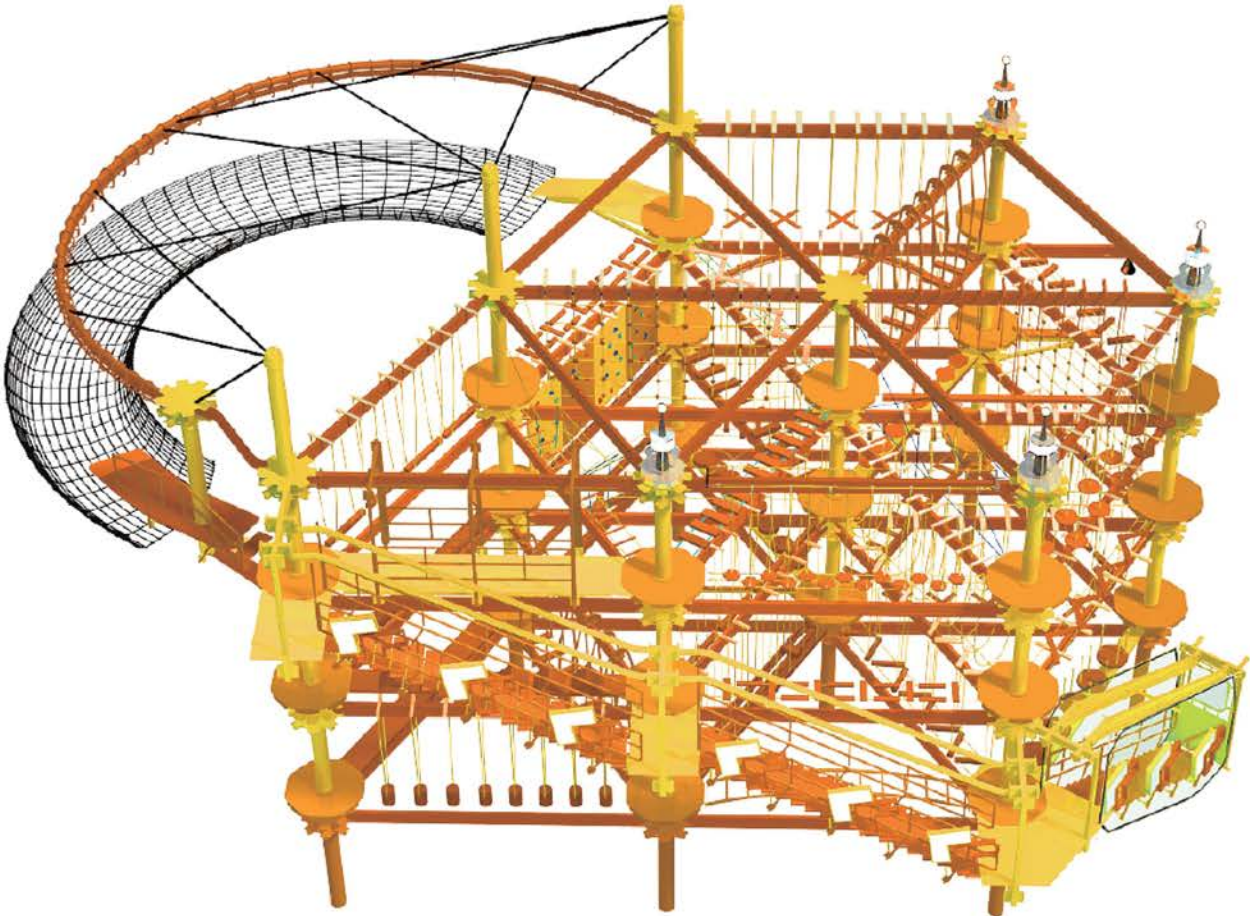

Reference size

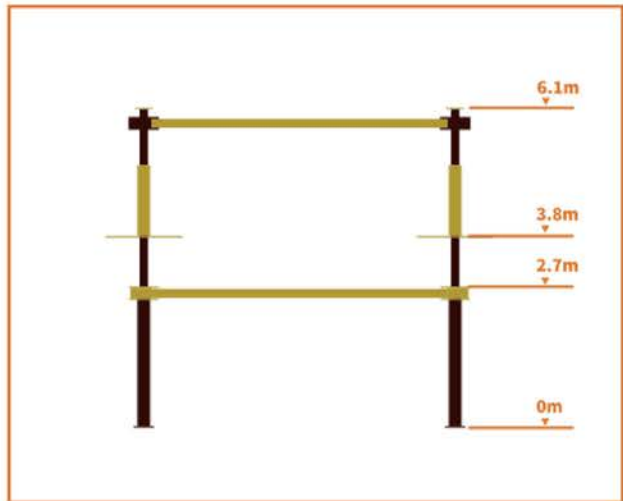
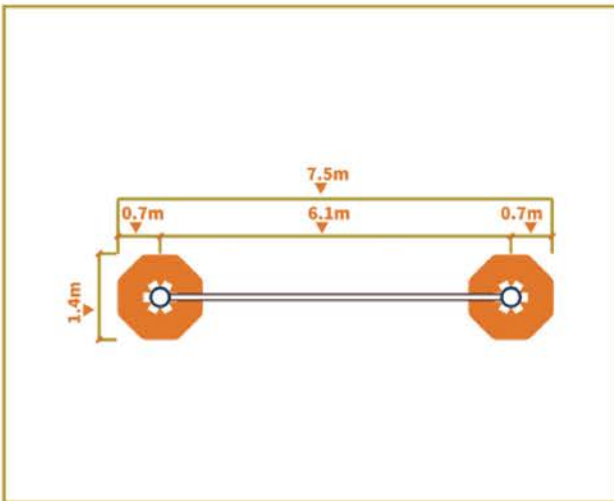

Obstacle Project

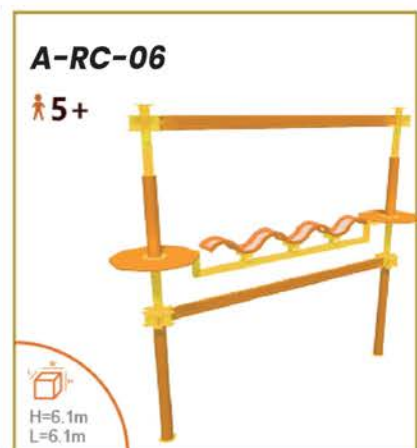



Sky Fly

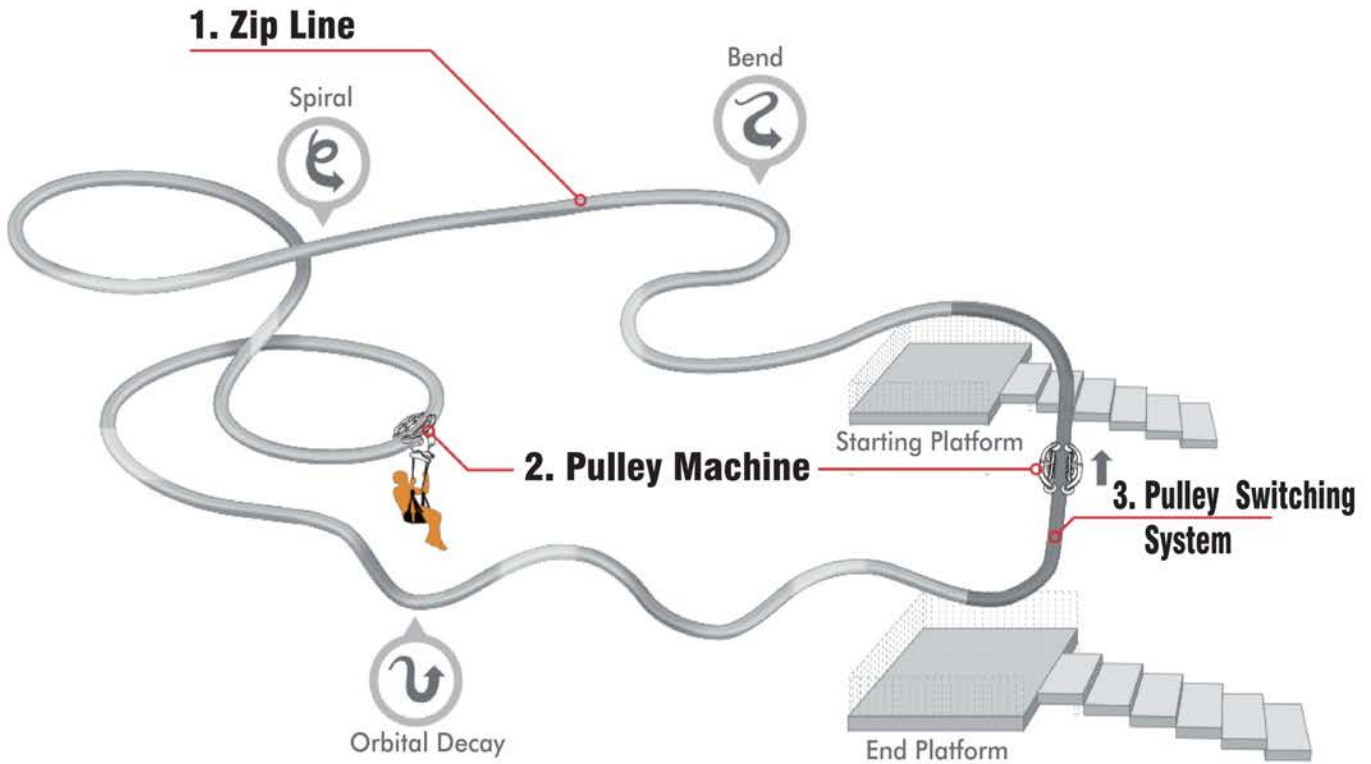

Applicable Venues



Operating Efficiency

(Subject to Actual Design)

Up to **60** Person per Hour

Speed

(Subject to Actual Design)

Up to **12** KM/H

Ninja Course

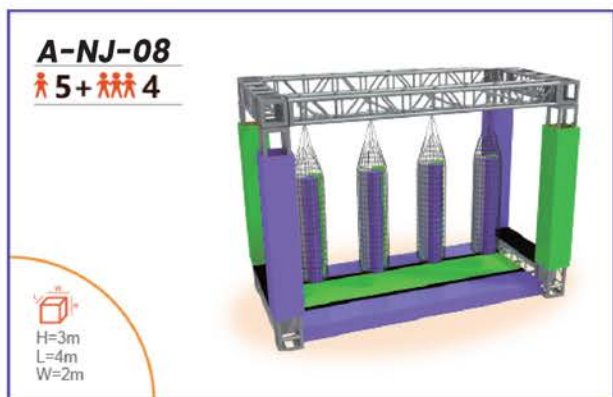
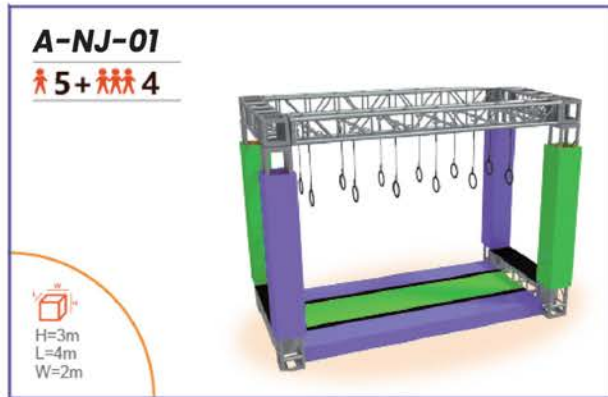

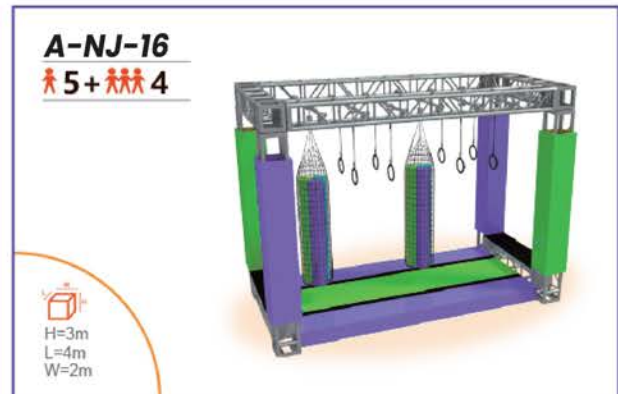
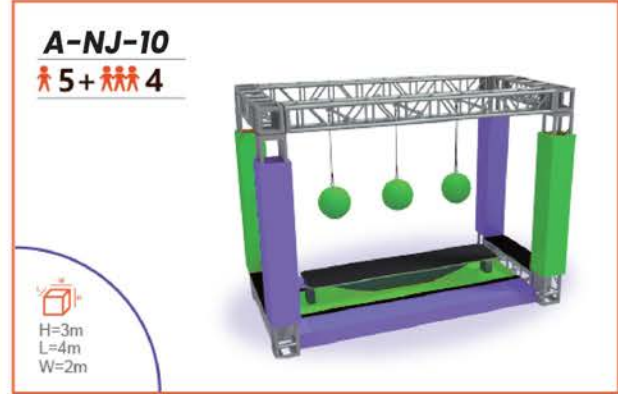



.....

Ground Obstacle

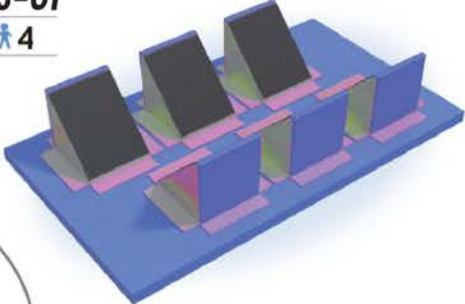
A-GNJ-01
 5+ 4



 H=3m
L=4m
W=2m

A-GNJ-02
 5+ 4

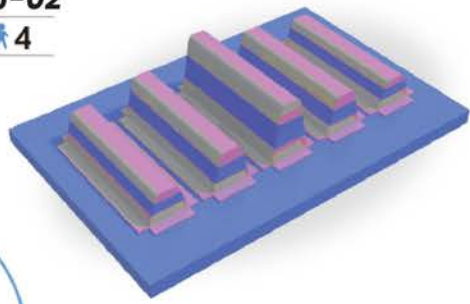

 H=3m
L=4m
W=2m

A-GNJ-03
 5+ 4

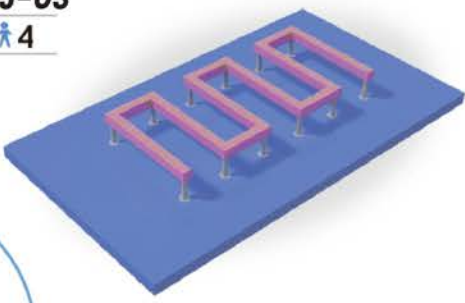

 H=3m
L=4m
W=2m

A-GNJ-04
 5+ 4

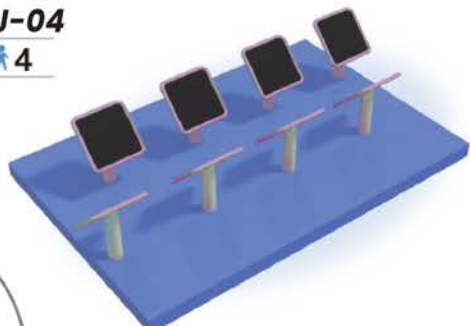

 H=3m
L=4m
W=2m

A-GNJ-05
 5+ 4

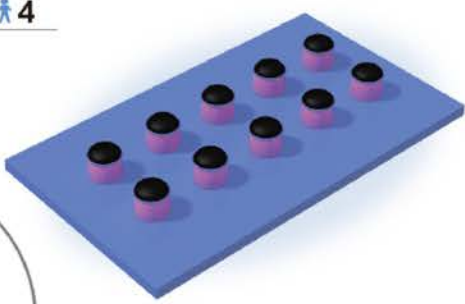

 H=3m
L=4m
W=2m

A-GNJ-06
 5+ 4

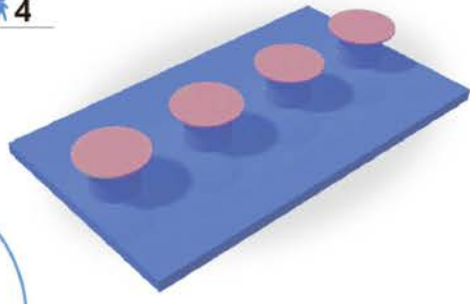

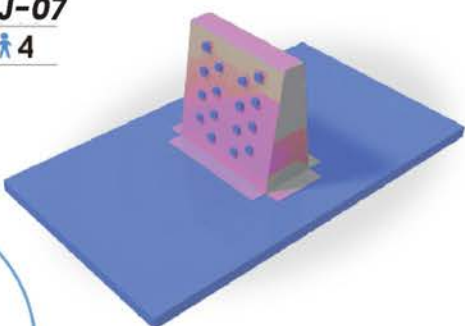

 H=3m
L=4m
W=2m

A-GNJ-07
 5+ 4



 H=3m
L=4m
W=2m

A-GNJ-08
 5+ 4



 H=3m
L=4m
W=2m

.....

Climbing Wall

A-CW-01



A-CW-02

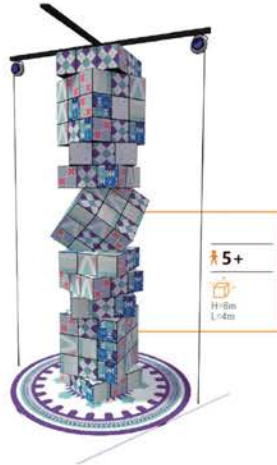

A-CW-03



A-CW-04



A-CW-05

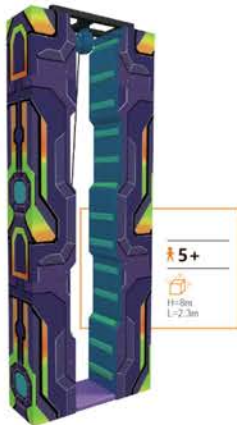

A-CW-06

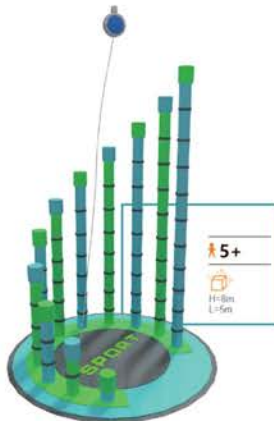

A-CW-07



A-CW-08

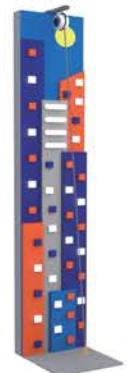

A-CW-09



A-CW-10



A-CW-11



A-CW-12



.....

Interactive Game

A-EL-01

5+

L=5m
W=7m
H=4m



A-EL-02

5+

L=5m
W=1.1m
H=2m



A-EL-03

5+

L=5m
W=7m
H=4m





A-EL-04

5+

L=5m
W=7m
H=4m



A-EL-05

5+

L=1.8m
W=1.8m
H=8m



A-EL-06

5+

L=6m
W=4m
H=3m

.....

WORKING PROCEDURES:

DESIGN



FABRICATION



TRANSPORTATION



INSTALLATION



.....

FAQ

How should I get started to set up an indoor playground?

Research the concept : Adler offers a variety of indoor attractions, including indoor playground systems, trampoline parks, ninja warrior courses, climbing walls, and more. Familiarize yourself with these options and consider your target age group, location, and theme. Understanding the market and customer demand will help you define the vision for your playground.

Contact Adler' s team: Our experienced designers and consultants will discuss your ideas, site layout, and budget. We can provide guidance on equipment selection, layout design, and revenue potential. Adler can even prepare sample 3D renderings and a preliminary project estimate to help you plan your investment and operations.

Is Adler a manufacturer or a trade company?

Adler is a direct manufacturer of high-quality indoor amusement equipment. We operate our own modern production facility, allowing us to control every step of the manufacturing process and maintain strict quality standards. This factory-direct approach enables us to offer competitive pricing and fast customization. By cutting out middlemen, we ensure consistent product quality and provide exceptional value to our clients.

Can I tour your factory?

Certainly! You are always welcome to visit Adler' s state-of-the-art manufacturing facility. Our factory in Hubei Province, China is equipped with advanced machinery and quality-control processes. On a tour, you can observe our production lines in action—seeing everything from material cutting and molding to final assembly. We look forward to meeting you in person and demonstrating the craftsmanship and care behind our products.

Can I have a customized design for my indoor playground?

Absolutely. Our in-house design team excels at creating fully customized playgrounds. Provide us with your site' s layout, ceiling height, and any themes or activities you want, and we will develop a unique design tailored to your needs. You will receive detailed plans and 3D renderings for your review. Adler' s designers combine creativity and technical expertise to ensure your playground is both innovative and perfectly suited to your space.

Can you offer a full set of services, including design, manufacturing, transportation, and installation?

Yes. Adler provides a complete turnkey solution for your project :

Design & Planning : We create detailed layouts and 3D designs based on your site drawings and requirements.

Manufacturing : All equipment is built in-house in our factory, using high-quality, non-toxic materials and strict quality control.

Logistics : We handle the packing and international shipping process. Our experienced logistics team coordinates with freight forwarders to ensure safe transit and smooth customs clearance.

Installation : We provide comprehensive installation manuals and drawings. If needed, our trained technicians can travel to your site to supervise or perform the assembly and train your staff (installation service incurs an additional fee).

INTERNATIONAL STANDARDS

Adler's equipment is engineered to comply with major international safety standards. We follow or exceed:

ASTM (USA) : including ASTM F2970-15 (trampoline park safety standard) and relevant ASTM standards for playground equipment.

EN 1176 (Europe) : the European Standard for Playground Equipment Safety.

CE and TÜV (Europe) : our products carry CE certification and meet German TÜV safety requirements.

All materials we use are non-toxic and fire-retardant, and we conduct rigorous testing during production. If you have specific safety requirements or need certification for your country, just let us know. Adler will provide the necessary documentation and ensure compliance.

When can I fully recover my investment, and how much profit can I expect?

Indoor playgrounds generally offer a healthy return on investment, but the exact payback period depends on many factors (such as location, ticket pricing, and operating costs). Adler can share case studies and sample financial models from similar projects to help you estimate your own ROI. We encourage you to perform a local market analysis for accurate projections. In many cases, well-managed play centers recoup their investment within a few years thanks to strong, steady demand from families.

I have never imported products from another country. Is the import process a hassle?

At Adler, we provide flexible shipping and logistics support tailored to the terms agreed upon with each client. Depending on the specific trade terms selected, we offer different levels of service to ensure your equipment is delivered safely and efficiently.

Our experienced logistics team will coordinate the export process and provide the necessary documentation to support smooth international delivery. With our global shipping experience, you can trust Adler to handle each step of the process professionally and reliably.

Do you offer any installation service?

Yes. Adler provides support for installation :

Installation Guides : We supply detailed assembly drawings and step-by-step instructions for all equipment.

On-Site Support : If desired, we can send our experienced technicians to your site to supervise or carry out the installation. They will also train your team on proper assembly and equipment operation.

Cost : Professional installation service is optional and incurs an additional fee (depending on project size and location).

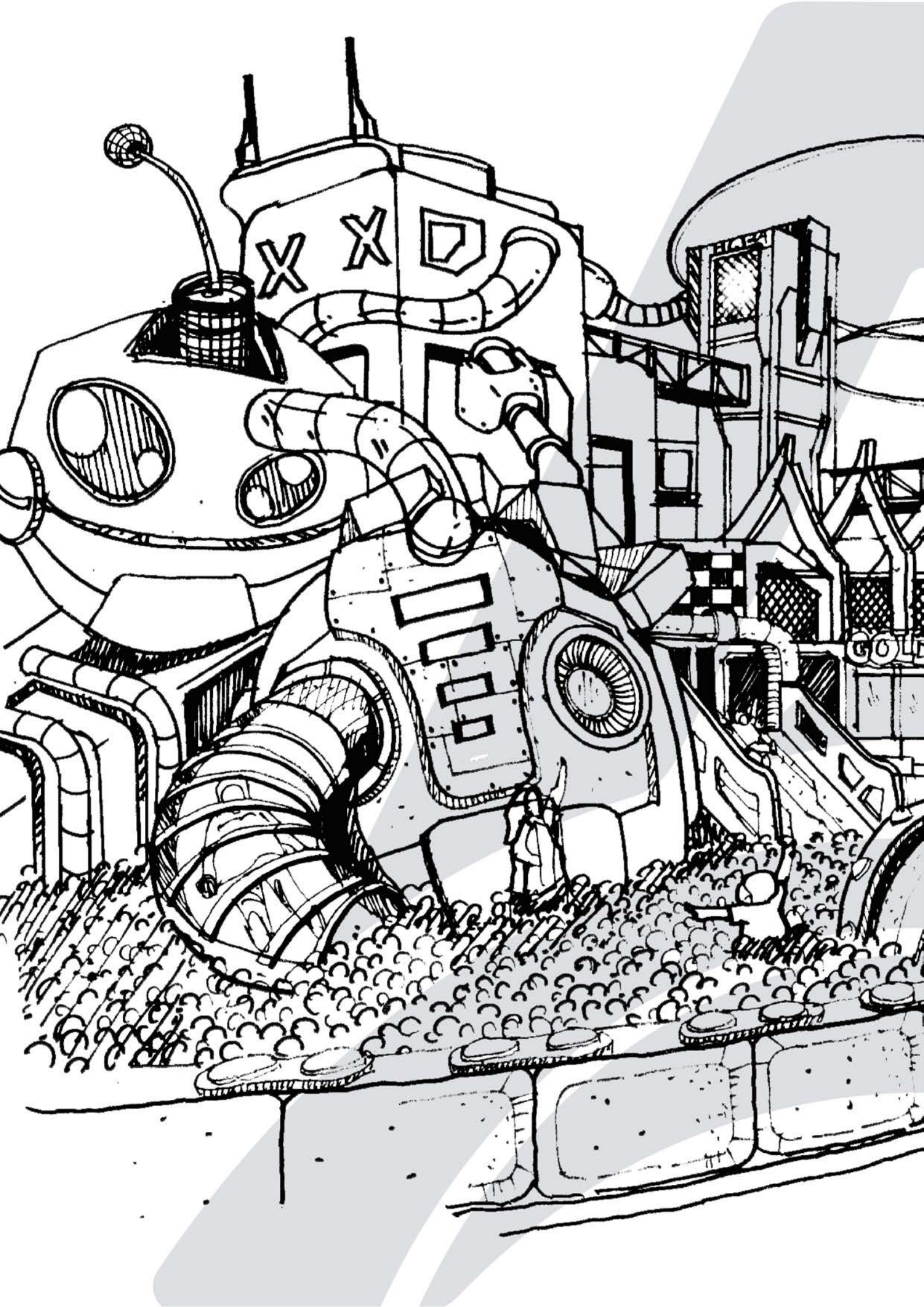



*Transforming Visions into Reality



ONLY MAKE EXQUISITE ITEMS

ADLER AMUSEMENT EQUIPMENT CO.,LTD

Beijing: Floor 6, Building 19, Chaobaiyun Valley, Yanjiao Development Zone, Sanhe City, Hebei Province, China

Shanghai: Floor 9, Building 6, Baolong Commercial Center, Hope Road, Jiading District, Shanghai, China

Wuhan: Adler Factory, Xishui County, Huanggang, Hubei Province, China

E-mail: sales@adlerplay.com

<http://www.adlerplay.com>